

BGSF110GN26

SP10T Antenna Switch Module with  
GPIO Interface, 2 GSMTX Ports for  
multi-mode GSM/EDGE, WCDMA or  
LTE Applications

Main RF Frontend Applications

Application Note AN306

Revision: Rev. 1.0

2014-11-28

**Edition 2015-01-21**

**Published by  
Infineon Technologies AG  
81726 Munich, Germany**

**© 2015 Infineon Technologies AG  
All Rights Reserved.**

#### **LEGAL DISCLAIMER**

THE INFORMATION GIVEN IN THIS APPLICATION NOTE IS GIVEN AS A HINT FOR THE IMPLEMENTATION OF THE INFINEON TECHNOLOGIES COMPONENT ONLY AND SHALL NOT BE REGARDED AS ANY DESCRIPTION OR WARRANTY OF A CERTAIN FUNCTIONALITY, CONDITION OR QUALITY OF THE INFINEON TECHNOLOGIES COMPONENT. THE RECIPIENT OF THIS APPLICATION NOTE MUST VERIFY ANY FUNCTION DESCRIBED HEREIN IN THE REAL APPLICATION. INFINEON TECHNOLOGIES HEREBY DISCLAIMS ANY AND ALL WARRANTIES AND LIABILITIES OF ANY KIND (INCLUDING WITHOUT LIMITATION WARRANTIES OF NON-INFRINGEMENT OF INTELLECTUAL PROPERTY RIGHTS OF ANY THIRD PARTY) WITH RESPECT TO ANY AND ALL INFORMATION GIVEN IN THIS APPLICATION NOTE.

#### **Information**

For further information on technology, delivery terms and conditions and prices, please contact the nearest Infineon Technologies Office ([www.infineon.com](http://www.infineon.com)).

#### **Warnings**

Due to technical requirements, components may contain dangerous substances. For information on the types in question, please contact the nearest Infineon Technologies Office.

Infineon Technologies components may be used in life-support devices or systems only with the express written approval of Infineon Technologies, if a failure of such components can reasonably be expected to cause the failure of that life-support device or system or to affect the safety or effectiveness of that device or system. Life support devices or systems are intended to be implanted in the human body or to support and/or maintain and sustain and/or protect human life. If they fail, it is reasonable to assume that the health of the user or other persons may be endangered.



## Table of Contents

<b>1</b>	<b>Introduction .....</b>	<b>6</b>
<b>2</b>	<b>BGSF110GN26 Features .....</b>	<b>6</b>
2.1	Main Features .....	6
2.2	Functional Diagram .....	6
2.3	Pin Configuration.....	7
2.4	Pin Description .....	7
<b>3</b>	<b>Application .....</b>	<b>8</b>
3.1	Application Board .....	9
<b>4</b>	<b>Small-Signal Characteristics.....</b>	<b>10</b>
4.1	Insertion Loss from Antenna Port to Respective RF Ports .....	10
4.2	Forward transmission GSM Tx.....	11
4.3	Reflection Antenna Port to all Ports .....	13
4.4	Port Reflection GSM Tx Ports .....	14
4.5	Isolation .....	15
<b>5</b>	<b>Non-Linear Performance of BGSF110GN26 .....</b>	<b>16</b>
5.1	Intermodulation.....	16
5.1.1	Intermodulation Measurement Setup .....	17
5.1.2	Intermodulation Measurement conditions .....	18
5.1.3	IMD Test Results for Band 1 and 5 .....	18
<b>6</b>	<b>Harmonic Distortion.....</b>	<b>19</b>
6.1.1	Harmonic Generation Measurement conditions.....	19
<b>7</b>	<b>Abbreviations .....</b>	<b>21</b>
<b>8</b>	<b>Authors.....</b>	<b>22</b>

## List of Figures

Figure 1	BGSF110GN26 functional diagram.....	6
Figure 2	BGSF110GN26 pin configuration.....	7
Figure 3	BGSF110GN26 in a mobile phone front end .....	8
Figure 4	Layout of the application board .....	9
Figure 5	Layout of de-embedding “ through” and “half” boards .....	9
Figure 6	PCB layer information .....	10
Figure 7	Application circuit .....	10
Figure 8	Forward transmission antenna port to TRx ports.....	11
Figure 9	Forward transmission GSM Tx ports.....	12
Figure 10	Forward transmission TRx2 over temperature.....	12
Figure 11	Reflection antenna port to all TRx ports.....	13
Figure 12	Port reflection GSM Tx ports.....	14
Figure 13	Isolation neighbour ports .....	15
Figure 14	Isolation TRx to TX1 port .....	15
Figure 15	Isolation TRx to Rx2 port.....	16
Figure 16	Block diagram of RF switch intermodulation.....	17
Figure 17	Intermodulation measurement test setup.....	17
Figure 18	Set-up for harmonics measurement.....	19
Figure 19	Harmonics at $f_{in}=824$ MHz.....	20
Figure 20	Harmonics at $f_{in}=1710$ MHz.....	20

## List of Tables

Table 1	Pin description (top view) .....	7
Table 2	Insertion loss from antenna port to RF ports (all other ports terminated with 50Ohm resistance) ..	10
Table 3	Insertion loss from antenna port to GSM Tx ports (all other ports terminated with 50 Ohm resistance).....	11
Table 4	Return loss from antenna port to RF ports (all other ports terminated with 50Ohm resistance) .....	13
Table 5	Return loss from antenna port to GSM Tx ports (all other ports terminated with 50-Ohm resistance)	14
Table 6	Test conditions of IMD measurements.....	18
Table 7	IMD measurements .....	18
Table 8	Harmonic generation measurement conditions .....	19

## 1 Introduction

The BGSF110GN26 is a Single-Pole Ten-Throw (SP10T) Antenna Switch Module (ASM) optimized for mobile phone and wireless applications for operating frequencies up to 3.8 GHz. It is a perfect solution for multi-mode handsets based on quadband GSM, WCDMA and LTE. The switch module configuration is shown in Figure 1 and supports a wide supply voltage range of 2.4 to 3.3 V.

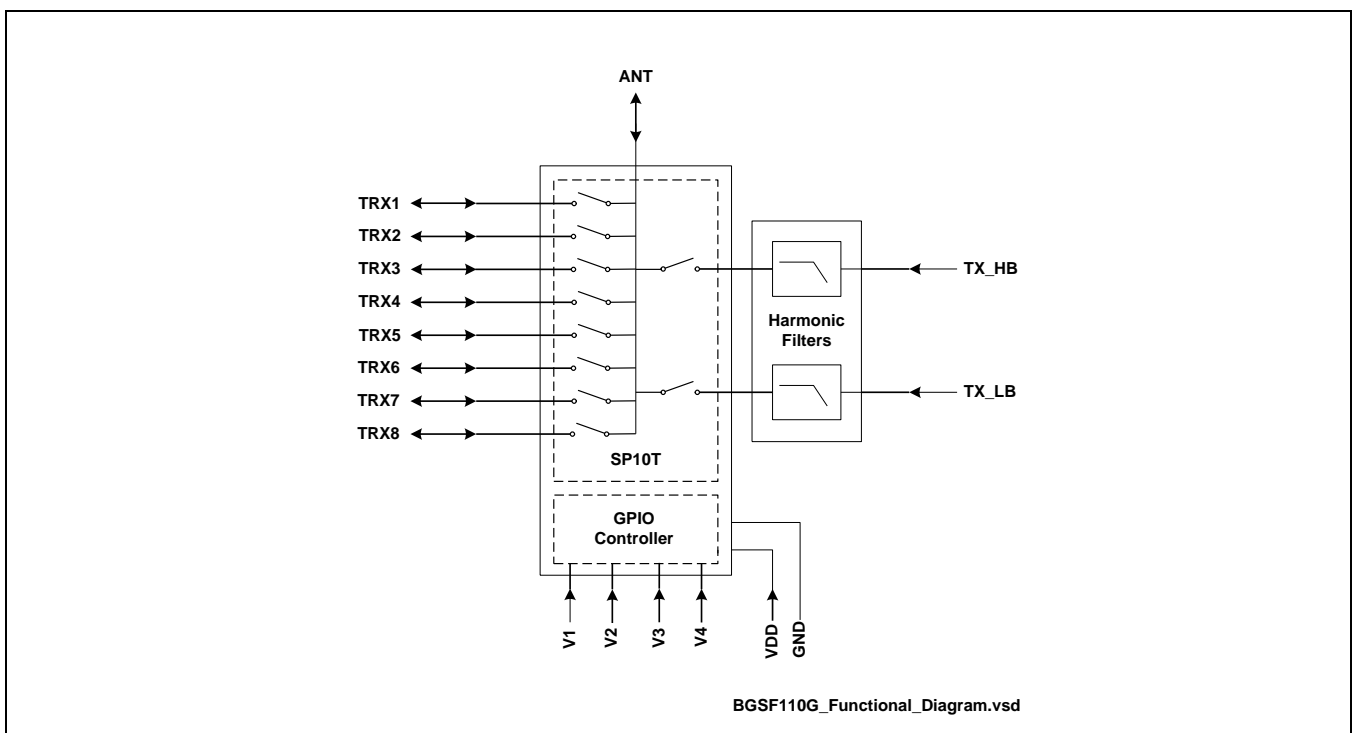
The module comes in a miniature TSNP package and is comprised of a high power CMOS SP10T switch, an integrated GPIO controller, and harmonic filters for GSM low-band and high-band transmit paths. The on-chip controller integrates CMOS logic and level shifters, driven by control inputs from 1.35 to 3.1 V. External DC blocking capacitors are not required in typical applications provided that DC voltages are not applied to any RF port.

## 2 BGSF110GN26 Features

### 2.1 Main Features

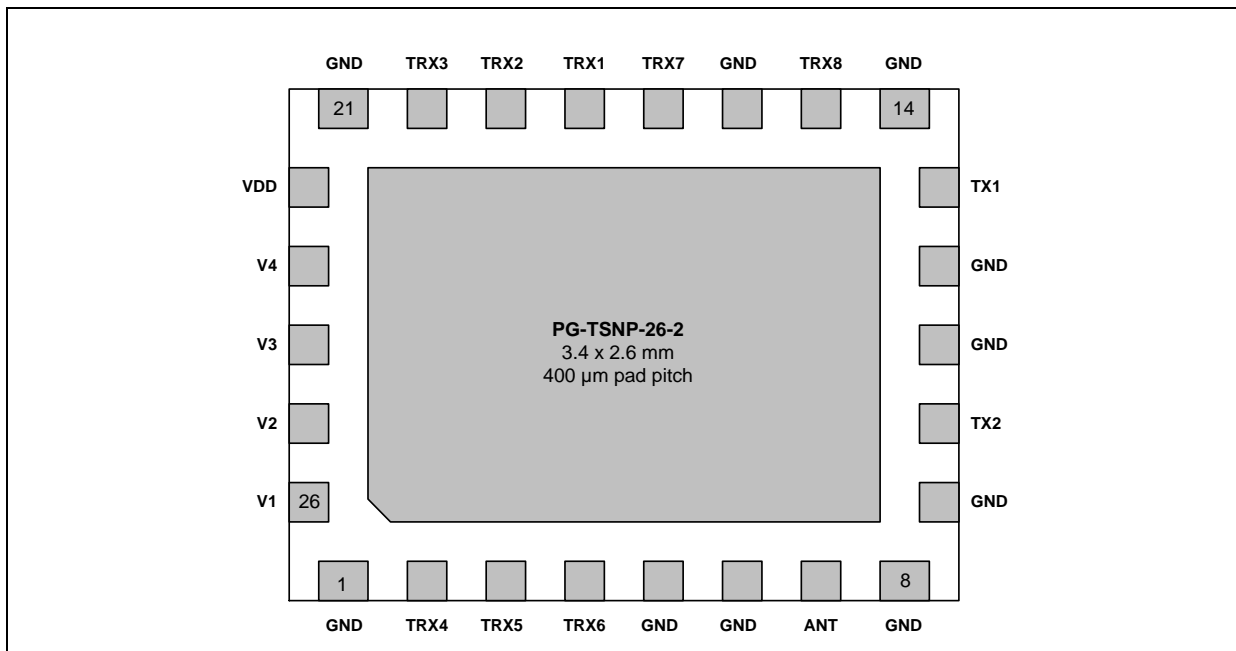
- Suitable for multi-mode GSM / EDGE / WCDMA / LTE / LTE-Advanced applications
- Frequency range of 100 MHz to 2.7 GHz
- Ultra-low insertion loss
- Integrated GSM transmit filters
- 8 interchangeable, high-linearity WCDMA TRX ports
- 2 high-linearity GSM TX paths
- High port-to-port isolation
- Integrated MIPI RFFE interface
- No DC decoupling capacitors required, if no DC applied on RF lines
- Small form factor: 3.2 mm x 2.8 mm x 0.73 mm

### 2.2 Functional Diagram



**Figure 1** BGSF110GN26 functional diagram

### 2.3 Pin Configuration



**Figure 2 BGSF110GN26 pin configuration**

### 2.4 Pin Description

**Table 1 Pin description (top view)**

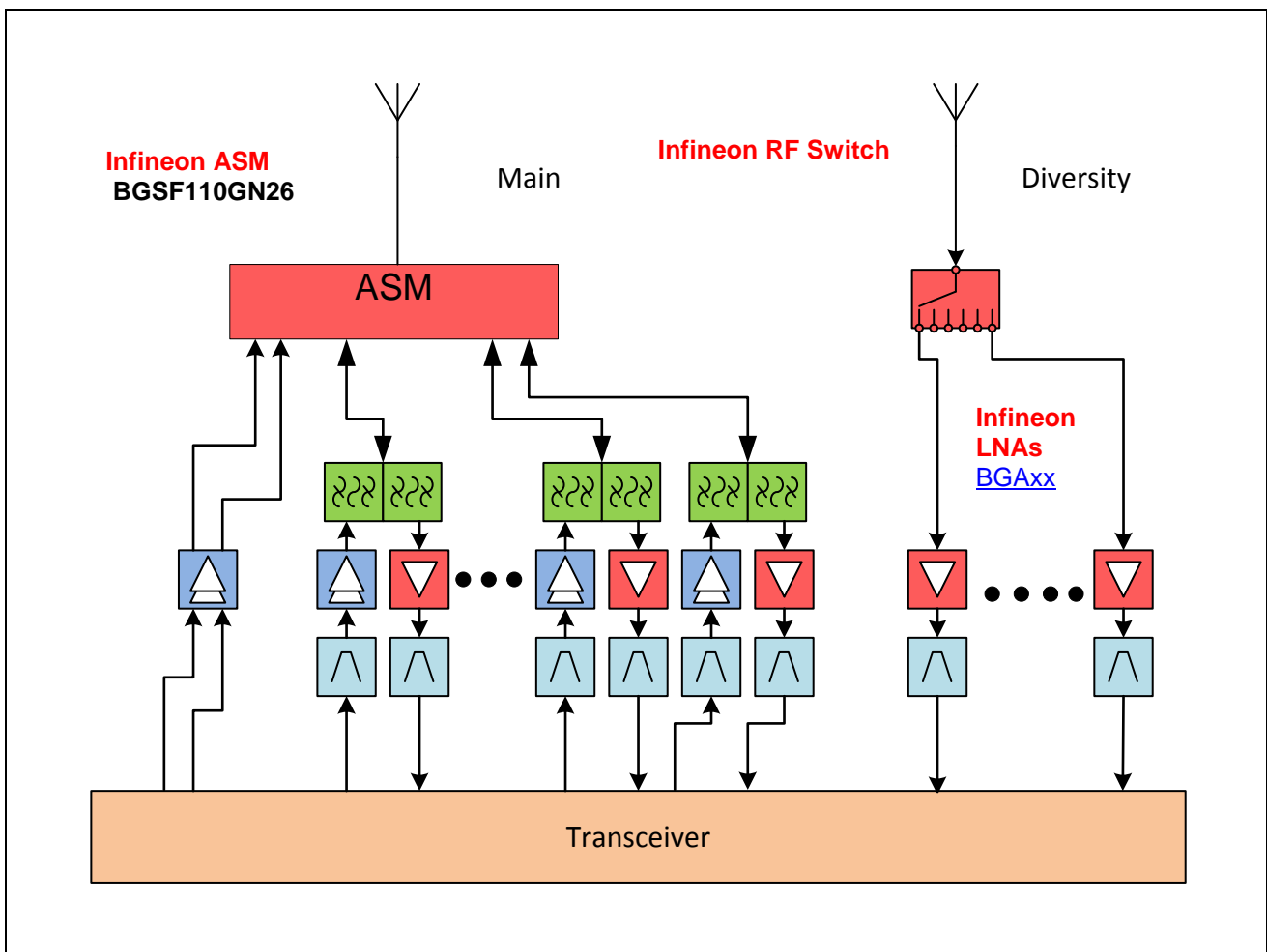
Pin NO	Name	Pin Type	Function
0	GND	GND	Ground, die pad
1	GND	GND	DC ground
2	TRX4	I/O	WCDMA TRX port
3	TRX5	I/O	WCDMA TRX port
4	TRX6	I/O	WCDMA TRX port
5	GND	GND	RF ground
6	GND	GND	RF ground
7	ANT	I/O	Antenna port
8	GND	GND	RF ground
9	GND	GND	RF ground
10	TX2	I	GSM HB port
11	GND	GND	RF ground
12	GND	GND	RF ground
13	TX1	I	GSM LB port
14	GND	GND	RF ground
15	TRX8	I/O	WCDMA TRX port
16	GND	GND	RF ground
17	TRX7	I/O	WCDMA TRX port
18	TRX1	I/O	WCDMA TRX port
19	TRX2	I/O	WCDMA TRX port
20	TRX3	I/O	WCDMA TRX port

**Table 1 Pin description (top view)**

Pin NO	Name	Pin Type	Function
21	GND	GND	DC ground
22	VDD	PWR	Supply Voltage
23	V4	I	GPIO Control pin
24	V3	I	GPIO Control pin
25	V2	I	GPIO Control pin
26	V1	I	GPIO Control pin

### 3 Application

A typical use of the BGSF110GN26 ASM in a mobile-phone application is shown in [Figure 3](#). In the main antenna path of the RF front end, the Infineon BGSF110GN26 routes the antenna signal to the required band-dependent front end components (e.g. duplexers, filters, PA), which in turn are connected directly to the transceiver IC. For the diversity path, Infineon recommends its RF switches such as the BGS15AN16. Infineon also offers a broad portfolio of Low-Noise Amplifiers (LNAs) that are optimized for the receive path in mobile-phone applications.



**Figure 3 BGSF110GN26 in a mobile phone front end**



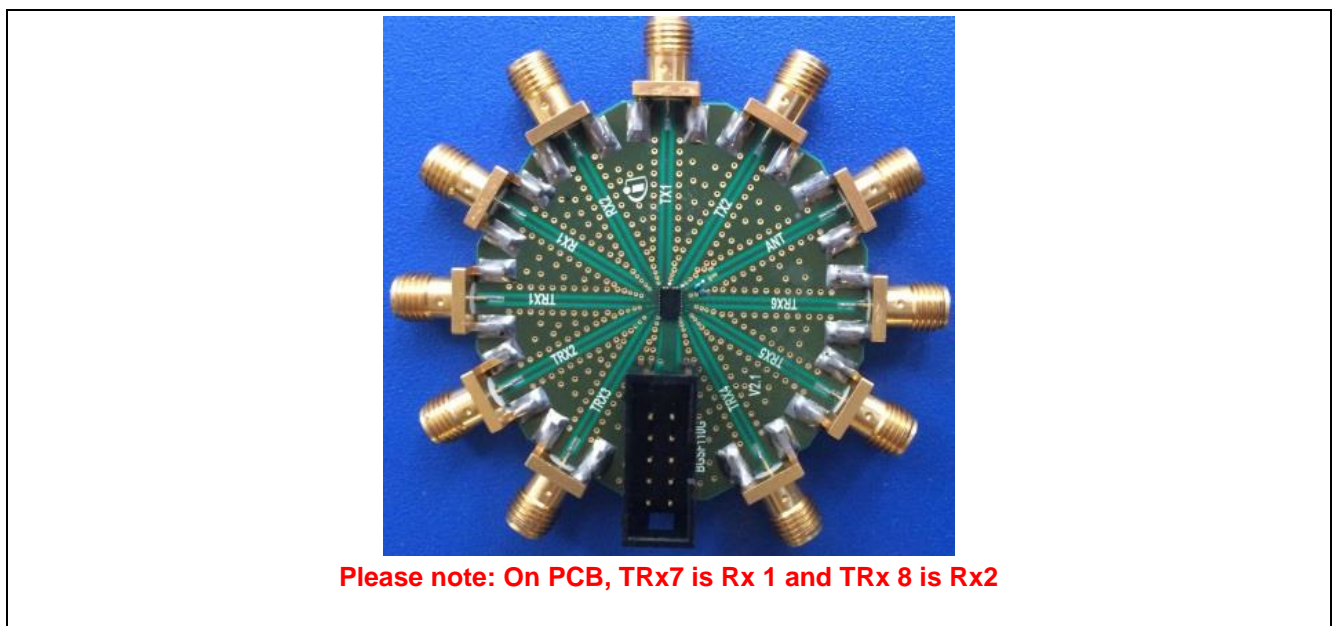
### 3.1 Application Board

Shown below is a picture of the Evaluation Board (EVB) used for all measurements (Figure 4). This EVB is designed such that all 50-Ohm connecting lines have the same length.

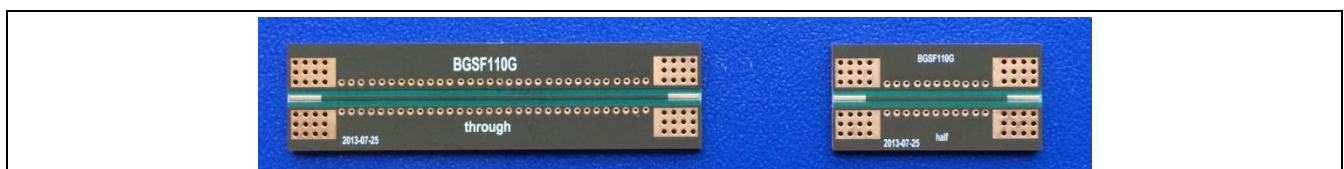
In order to obtain accurate values for insertion loss measurements of the BGSF110GN26, all influences and losses of the EVB, lines, and connectors have to be eliminated. Therefore a separate de-embedding board representing the line length is necessary (Figure 5).

The calibration of the NetWork Analyser (NWA) is done in six steps:

- 1) Perform full calibration on all NWA ports.
- 2) Attach special SMA connector (use same as soldered to EVB with no inner conductor) to port 2 and perform "open" port extension. Turn the port extensions on.
- 3) Connect the "half" de-embedding board (Figure 5 right board) between port 1 and port 2, and store this as an s-parameter (.s2p) file. Now turn all port extensions off.
- 4) Load the stored s-parameter file of the "half" de-embedding board as the de-embedding file for all NWA ports used.
- 5) Now switch all port extensions on.
- 6) Cross-check the insertion loss with the "through" de-embedding board (Figure 5 left board)

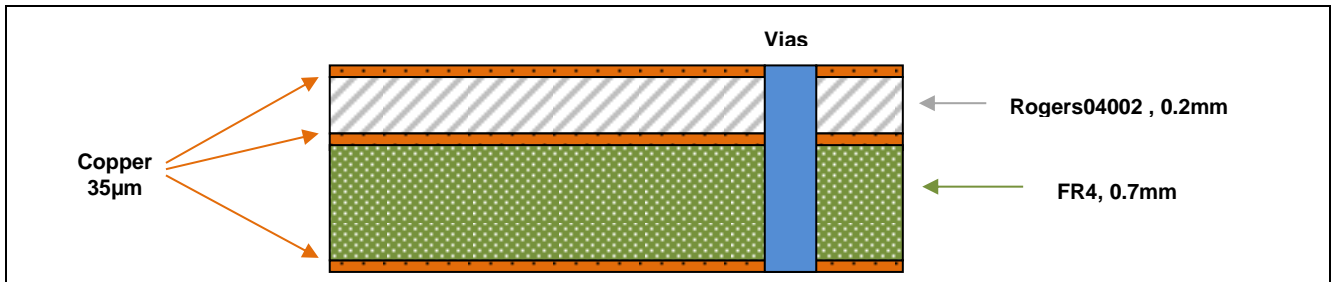


**Figure 4** Layout of the application board



**Figure 5** Layout of de-embedding "through" and "half" boards

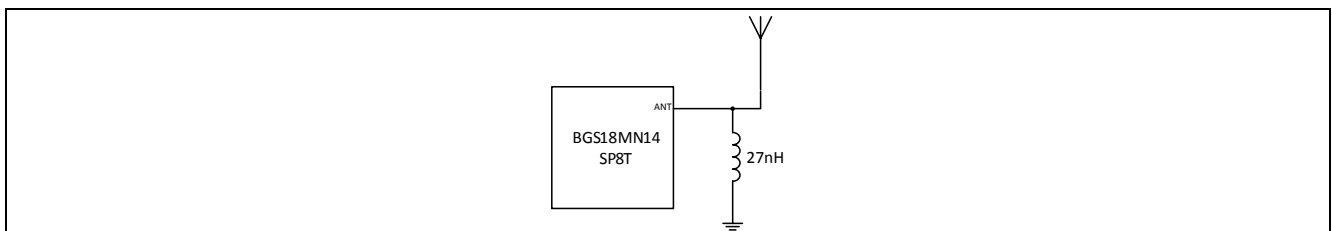
The EVB is made of a sandwich of FR4 and Rogers 04002, and has 3 layers. The layer stack is shown in Figure 6.



**Figure 6** PCB layer information

## 4 Small-Signal Characteristics

The small-signal characteristics were measured at 25 °C using a Vector Network Analyzer (VNA), a supply voltage, V<sub>dd</sub>, of 3.0 V, and the application circuit shown in [Figure 7](#).



**Figure 7** Application circuit

### 4.1 Insertion Loss from Antenna Port to Respective RF Ports

**Table 2** Insertion loss from antenna port to RF ports (all other ports terminated with 50Ohm resistance)

Frequency (MHz)	704	716	740	751	824	881	915	942	1710	1842	1960	1970	2017	2140	2170	2350	2593	2690	3500
TRx1	0.62	0.62	0.61	0.61	0.6	0.6	0.59	0.6	0.69	0.71	0.73	0.73	0.75	0.79	0.8	0.89	1	1.1	1.7
TRx2	0.63	0.62	0.62	0.62	0.6	0.6	0.6	0.6	0.68	0.7	0.72	0.72	0.74	0.77	0.78	0.85	0.99	1.1	1.7
TRx3	0.65	0.64	0.64	0.64	0.61	0.61	0.61	0.61	0.67	0.68	0.7	0.7	0.71	0.75	0.76	0.83	0.97	1	1.6
TRx4	0.63	0.62	0.62	0.62	0.6	0.6	0.6	0.6	0.68	0.7	0.72	0.72	0.73	0.77	0.78	0.86	1	1.1	1.8
TRx5	0.62	0.61	0.61	0.61	0.61	0.62	0.62	0.62	0.74	0.75	0.76	0.76	0.77	0.81	0.82	0.9	1.1	1.2	2
TRx6	0.59	0.59	0.58	0.58	0.57	0.57	0.57	0.57	0.72	0.75	0.79	0.79	0.82	0.88	0.9	1	1.3	1.4	2.3
TRx7 (Rx1)	0.62	0.61	0.61	0.61	0.6	0.61	0.61	0.61	0.73	0.74	0.75	0.75	0.76	0.79	0.79	0.85	0.98	1	1.7
TRx8 (Rx2)	0.63	0.62	0.62	0.62	0.59	0.59	0.59	0.59	0.72	0.71	0.71	0.71	0.72	0.75	0.76	0.84	0.98	1	1.6

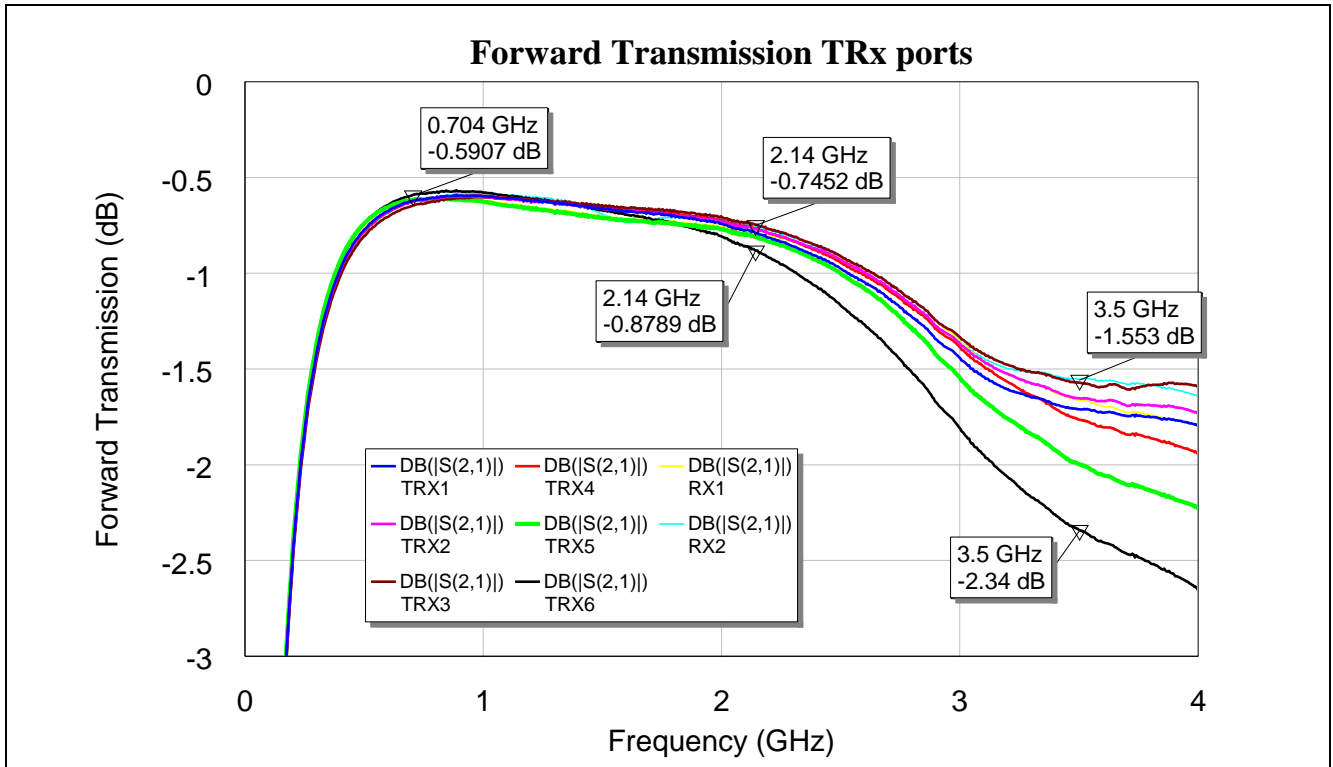


Figure 8 Forward transmission antenna port to TRx ports

## 4.2 Forward transmission GSM Tx

Table 3 Insertion loss from antenna port to GSM Tx ports (all other ports terminated with 50 Ohm resistance)

Frequency (MHz)	704	716	740	751	824	881	915	942	1710	1842	1960	1970	2017	2140	2170	2350	2593	2690	3500
Tx1(LB)	0.69	0.69	0.71	0.71	0.75	0.79	0.81	0.82	1.1	1.2	1.3	1.3	1.4	1.9	2.1	4	8.5	11	47
Tx2(HB)	1	1	1	1	1	0.97	0.96	0.97	43	31	28	28	28	28	28	30	36	41	25

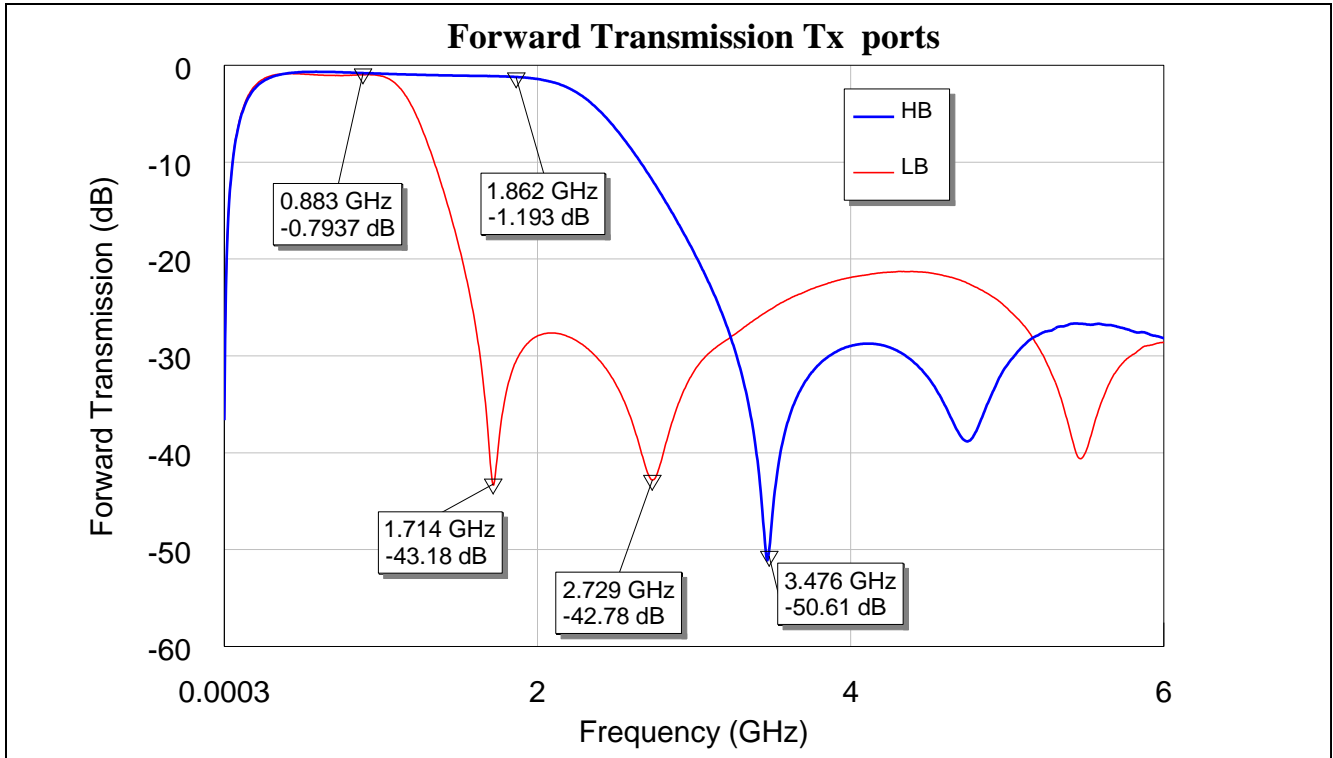


Figure 9 Forward transmission GSM Tx ports

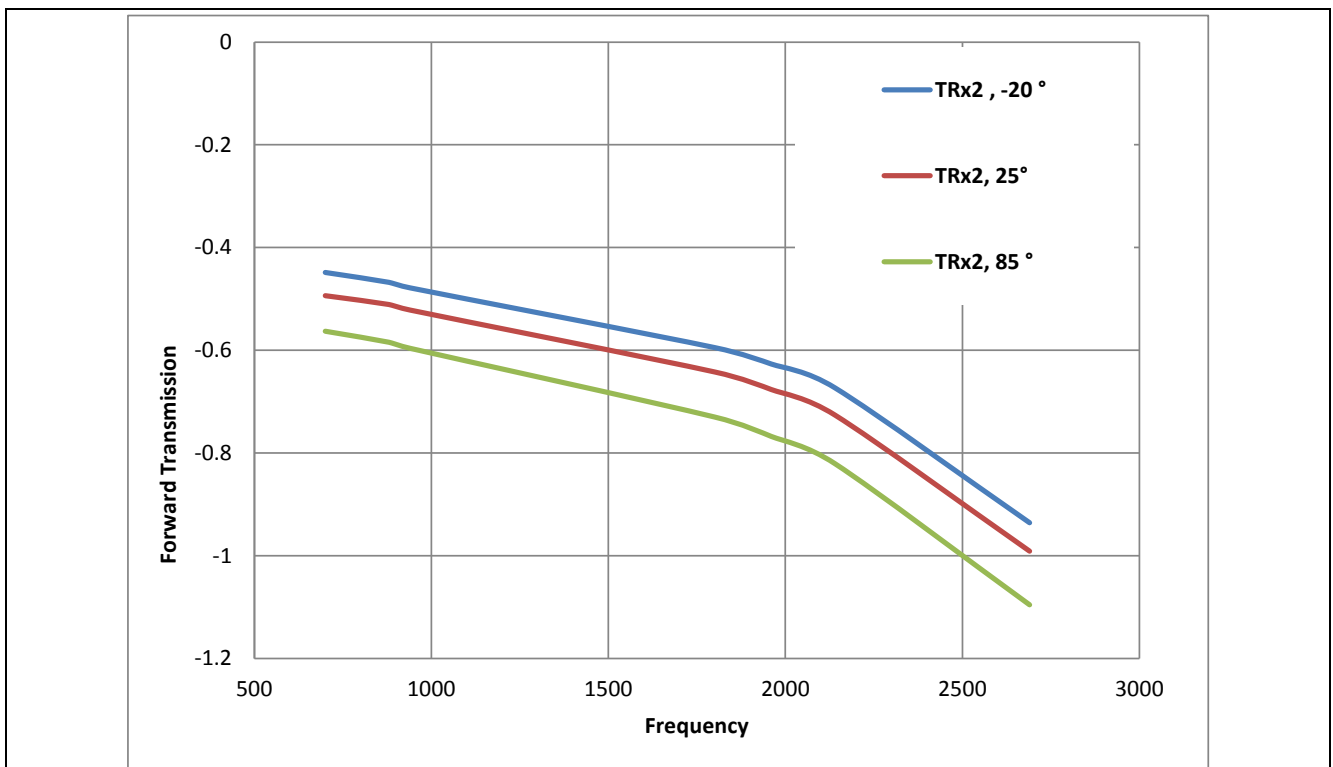
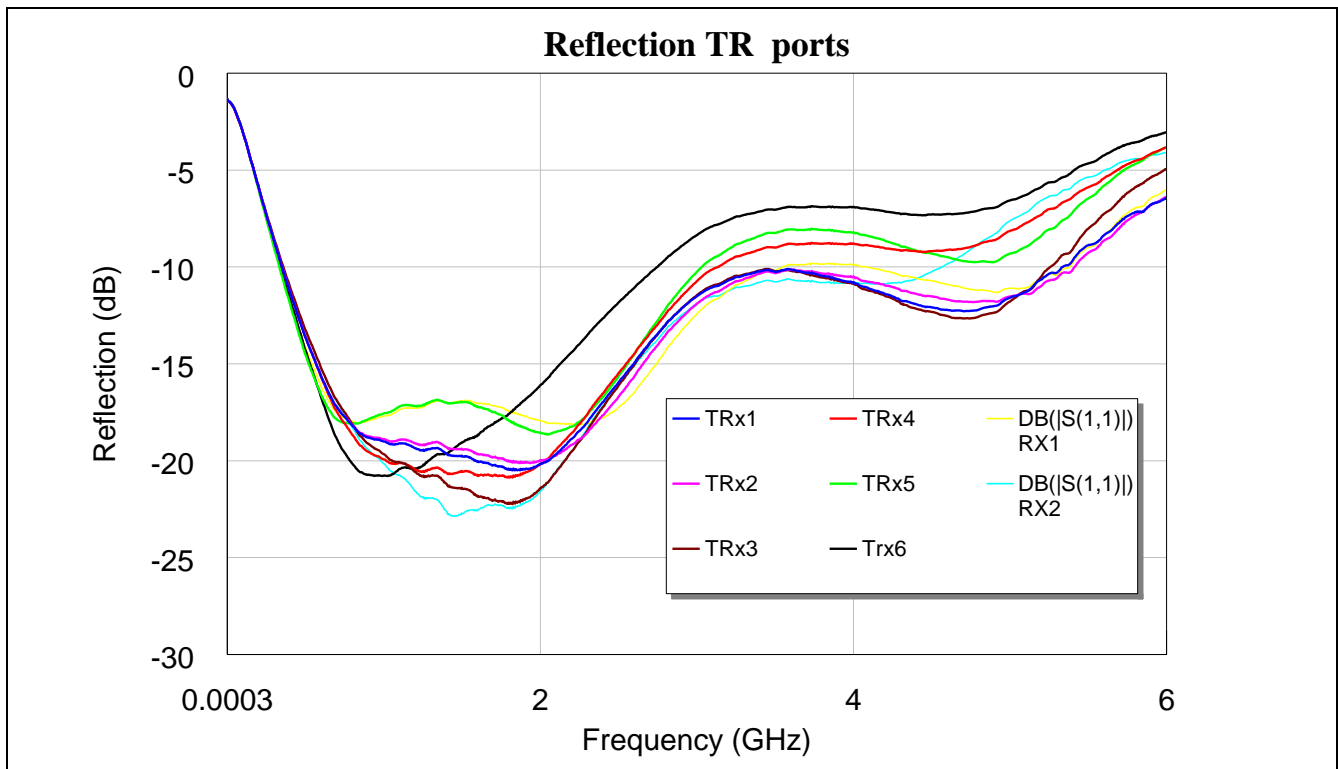


Figure 10 Forward transmission TRx2 over temperature

### 4.3 Reflection Antenna Port to all Ports

**Table 4** Return loss from antenna port to RF ports (all other ports terminated with 50Ohm resistance)

Frequency (MHz)	704	716	740	751	824	881	915	942	1710	1842	1960	1970	2017	2140	2170	2350	2593	2690	3500
TRx1	17.3	17.4	17.7	17.7	18.4	18.7	18.8	18.9	20.2	20.5	20.3	20.3	20.1	19.4	19.1	17.5	15	14	10.3
TRx2	17.3	17.4	17.6	17.7	18.4	18.7	18.8	18.8	19.8	20.1	20.1	20.1	20	19.5	19.4	18.1	15.7	14.6	10.3
TRx3	16.9	17.1	17.4	17.5	18.4	19	19.2	19.4	22	22.1	21.7	21.7	21.3	20.2	19.9	17.8	15.1	14.1	10.2
TRx4	17.5	17.7	18	18.1	18.9	19.4	19.6	19.7	20.7	20.8	20.4	20.4	20.1	19.1	18.8	17	14.6	13.5	9
TRx5	17.9	17.9	18	18	18.1	17.9	17.8	17.7	17.5	18.1	18.5	18.5	18.6	18.4	18.3	17.2	14.6	13.4	8.24
TRx6	18.9	19.1	19.5	19.6	20.4	20.7	20.7	20.8	18	17.3	16.4	16.4	16	14.9	14.7	13.1	11.1	10.4	7.05
TRx7 (Rx1)	17.5	17.6	17.8	17.8	18	18	17.9	17.9	17.1	17.5	17.8	17.9	18	18.1	18.1	17.9	16.6	15.5	10.2
TRx8 (Rx2)	17	17.2	17.5	17.6	18.6	19.3	19.5	19.8	22.2	22.4	21.9	21.8	21.5	20.1	19.8	17.7	15.2	14.3	10.8

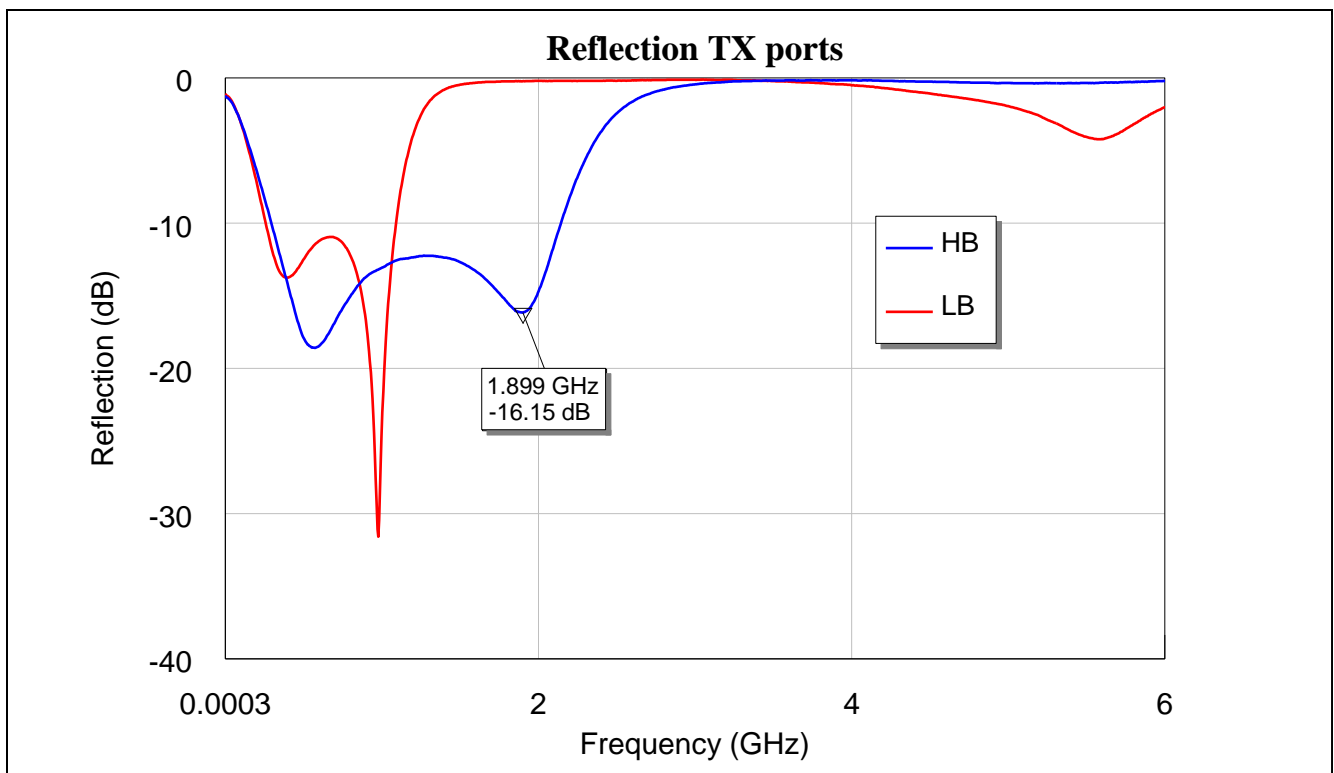


**Figure 11** Reflection antenna port to all TRx ports

#### 4.4 Port Reflection GSM Tx Ports

**Table 5** Return loss from antenna port to GSM Tx ports (all other ports terminated with 50-Ohm resistance)

Frequency (MHz)	704	716	740	751	824	881	915	942	1710	1842	1960	1970	2017
Tx1 (LB)	11.0	11.1	11.2	11.4	12.9	15.4	18.4	22.4					
Tx2 (HB)	18.2	18.0	17.6	17.4	16.1	15.2	14.9	14.7	13.1	12.9	11.7	11.6	10.8



**Figure 12** Port reflection GSM Tx ports

4.5 Isolation

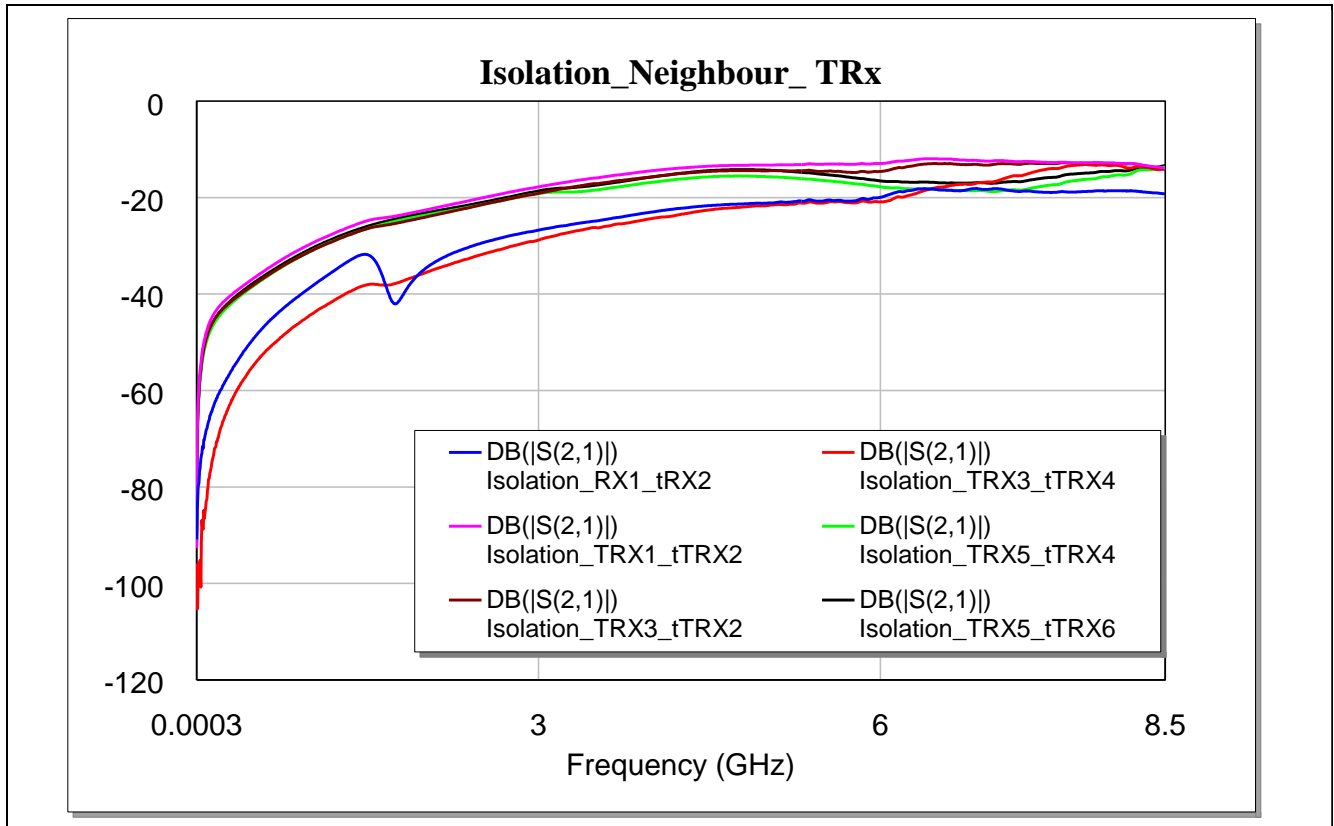


Figure 13 Isolation neighbour ports

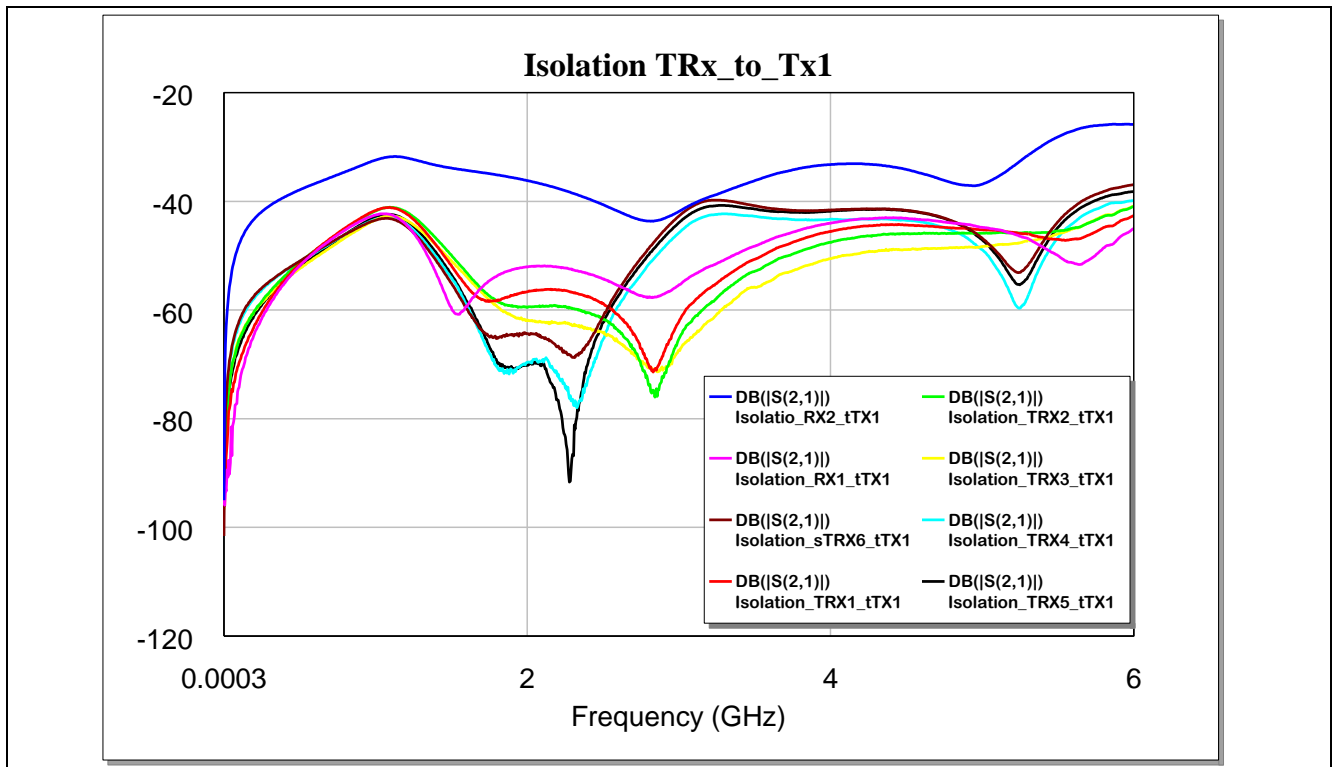
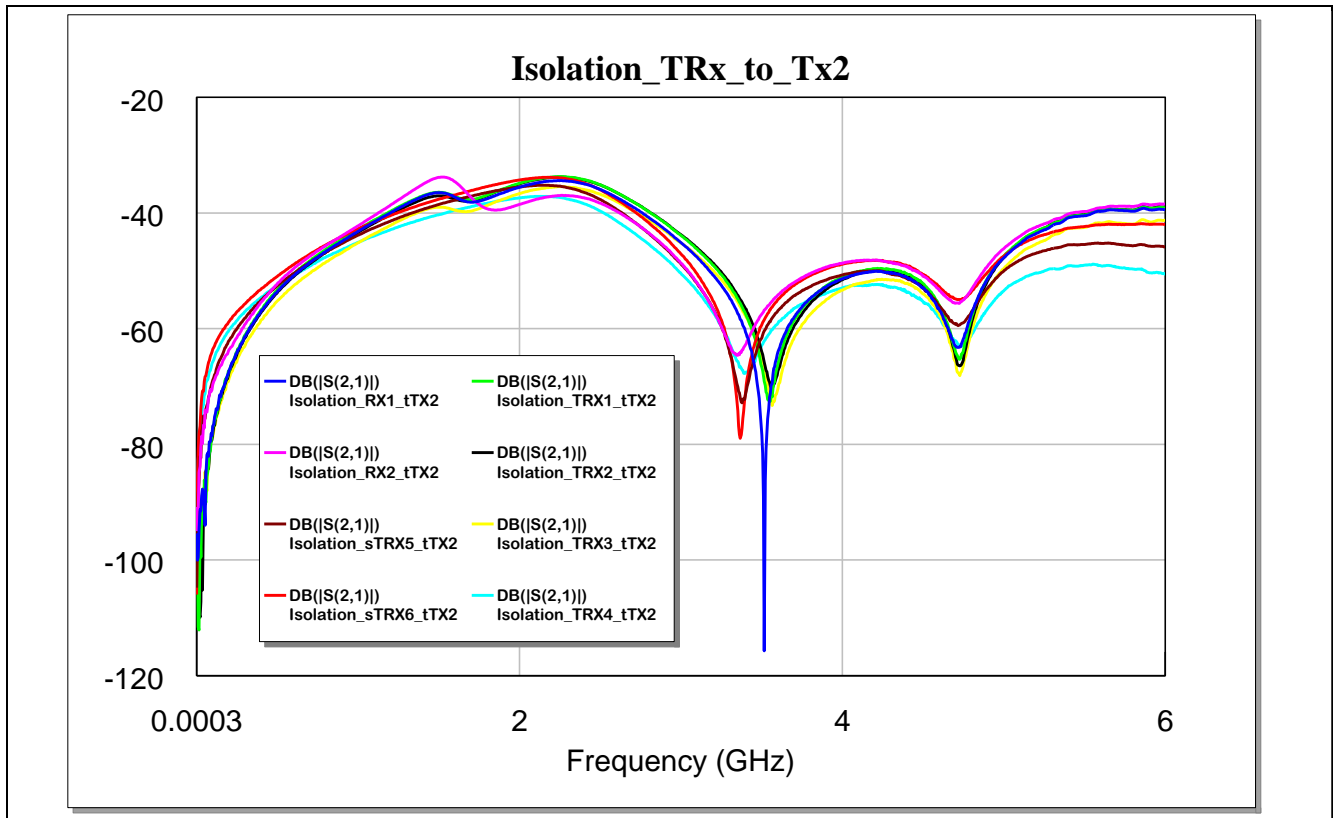


Figure 14 Isolation TRx to TX1 port



**Figure 15 Isolation TRx to Rx2 port**

## 5 Non-Linear Performance of BGSF110GN26

Smart phones today can operate across several cellular bands covering GSM / EDGE / CDMA / UMTS / WCDMA / LTE/TD-SCDMA / TD-LTE / LTE-A. The design of the RF front-end part in modern cellular phones is becoming increasingly complex and demanding due to the increasing number of frequency bands and modes that the phone needs to support. One of the main components of the RF front-end is the antenna switch that selects which transmitter (TX)/receiver (RX) path can be connected to the antenna. The RF switch has to satisfy high linearity requirements. The following material describes some of the main challenges of antenna switches in mobile applications.

Modern smartphones are multi-mode devices that are capable of connecting to 2G, 3G and 4G networks. These networks often use different frequency bands. The smartphone's RF frontend must therefore include band-specific components. In order to appropriately route signals for a given mode and band of operation, a high-performance RF switch is an essential component of the front-end circuitry. The performance requirements of the RF switch are discussed in the following sections.

### 5.1 Intermodulation

Intermodulation Distortion (IMD2 and IMD3) is a parameter that describes the linearity of a device under multi-tone conditions. The intermodulation between different frequency components generates undesired output frequencies at the sum and difference frequencies of the input tones, and at multiples of those sum and difference frequencies.





A requirement of the test setup for IMD measurements is high isolation between the RX and TX signals (Figure 17). In practice, a laboratory-grade duplexer with an isolation of 80 dB is used.

Table 6 shows the test specification for Band 1 and Band 5.

### 5.1.2 Intermodulation Measurement conditions

**Table 6 Test conditions of IMD measurements**

Band 1					
	TX		Interferer		IMD product
Test case	F <sub>IN</sub> (MHz)	P <sub>IN</sub> (dBm) CW	F <sub>IN</sub> (MHz)	P <sub>IN</sub> (dBm) CW	F <sub>IMD</sub> (MHz)
IMD3	1950	20	1760	-15	2140
IMD2 low			190		
IMD2 high			4090		
Band 5					
	F <sub>IN</sub> (MHz)	P <sub>IN</sub> (dBm) CW	F <sub>IN</sub> (MHz)	P <sub>IN</sub> (dBm) CW	F <sub>IMD</sub> (MHz)
IMD3	835	20	790	-15	880
IMD2 low			45		
IMD2 high			1715		

The results for Band 1 and Band 5 are given in Table 7.

### 5.1.3 IMD Test Results for Band 1 and 5

**Table 7 IMD measurements**

Band 1	TX		Interferer		Intermodulation Products UMTS Band 1		
	F <sub>IN</sub> (MHz)	P <sub>IN</sub> (dBm)	F <sub>IN</sub> (MHz)	P <sub>IN</sub> (dBm)	F <sub>IMD</sub> (MHz)	P <sub>IMD</sub> (dBm)	IIPx (dBm)
IMD3	1950	20	1760	-15	2140	-107	66
IMD2 low	1950	20	190	-15	2140	-93	98
IMD2 high	1950	20	4090	-15	2140	-104	109

Band 5	TX		Interferer		Intermodulation Products UMTS Band 5		
	F <sub>IN</sub> (MHz)	P <sub>IN</sub> (dBm)	F <sub>IN</sub> (MHz)	P <sub>IN</sub> (dBm)	F <sub>IMD</sub> (MHz)	P <sub>IMD</sub> (dBm)	IIPx (dBm)
IMD3	835	20	790	-15	880	-123	74
IMD2 low	835	20	45	-15	880	-92	97
IMD2 high	835	20	1715	-15	880	-105	110

## 6 Harmonic Distortion

Harmonic distortion is another important parameter for the characterization of an RF switch. RF switches have to withstand high RF levels, up to 36 dBm. This high RF power at the input of a switch generates harmonics of the waveform that is present. These harmonics (2<sup>nd</sup> and 3<sup>rd</sup>) can interfere with other reception bands or can cause distortion in other RF applications (GPS, WLAN) within the mobile phone.

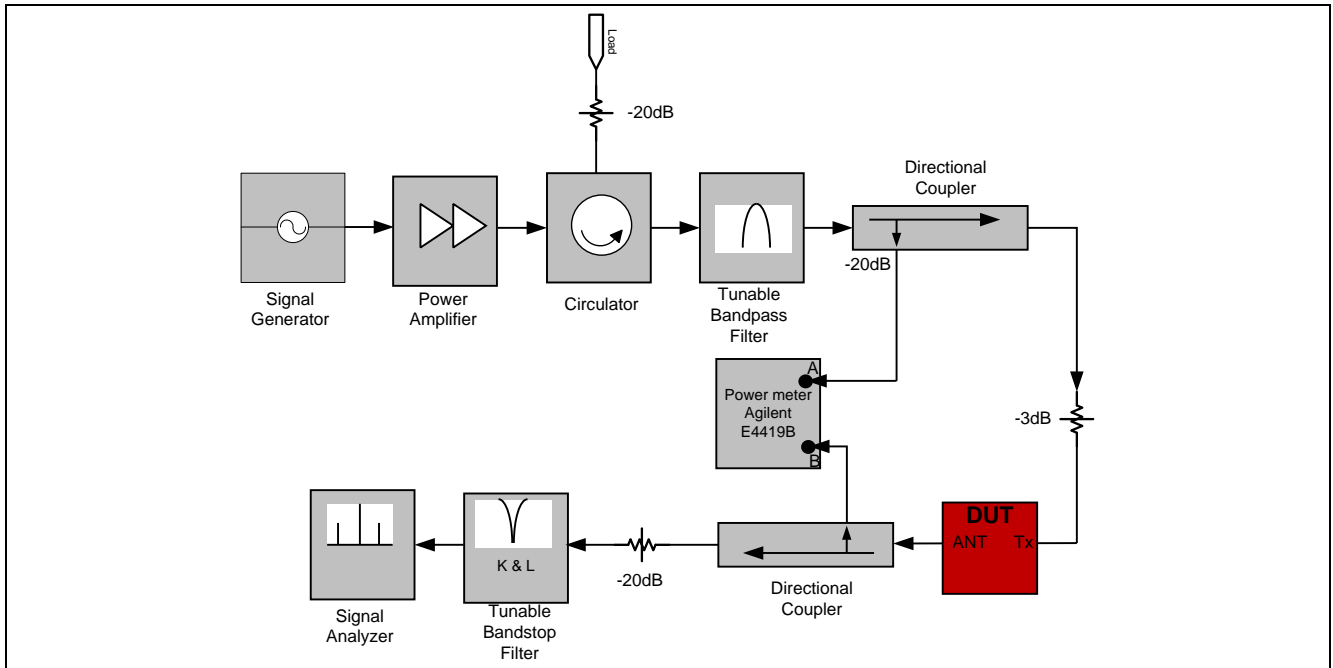


Figure 18 Set-up for harmonics measurement

### 6.1.1 Harmonic Generation Measurement conditions

Table 8 Harmonic generation measurement conditions

Tx		Harmonic Products	
$F_{IN}$ (MHz)	$P_{IN}$ (dBm), 50% DC	$F_{H2}$ (MHz)	$F_{H3}$ (MHz)
824	20...38 TX LB port	1648	2472
	20...30 TRX LB ports		
1800	20...38 TX HB port	3600	5400
	20...30 TRX HB ports		

The results for the harmonic generation at 824 MHz and 1710 MHz are shown in [Figure 19](#) for TX1 and [Figure 20](#) Tx2. The input power ( $P_{in}$ ) is plotted on the x axis, and the generated harmonics in dBm on the y axis.

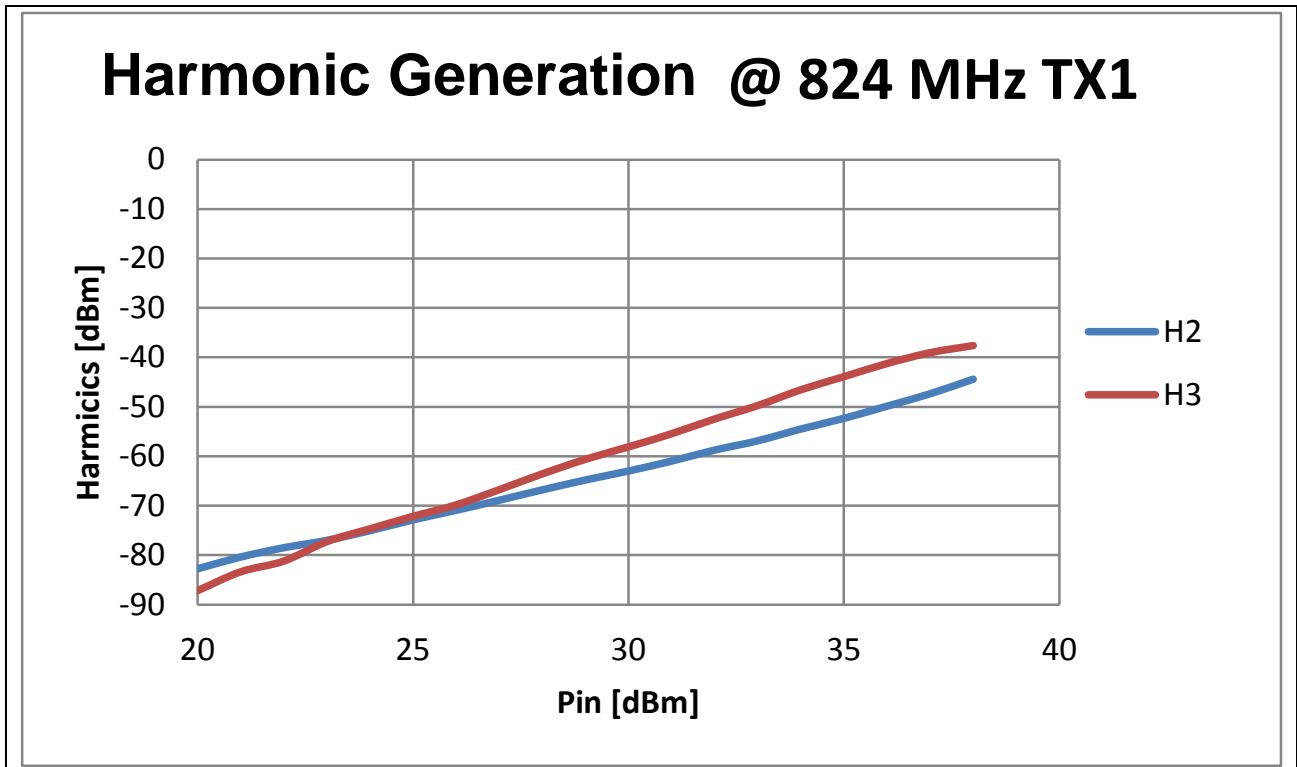


Figure 19 Harmonics at  $f_{in}=824$  MHz

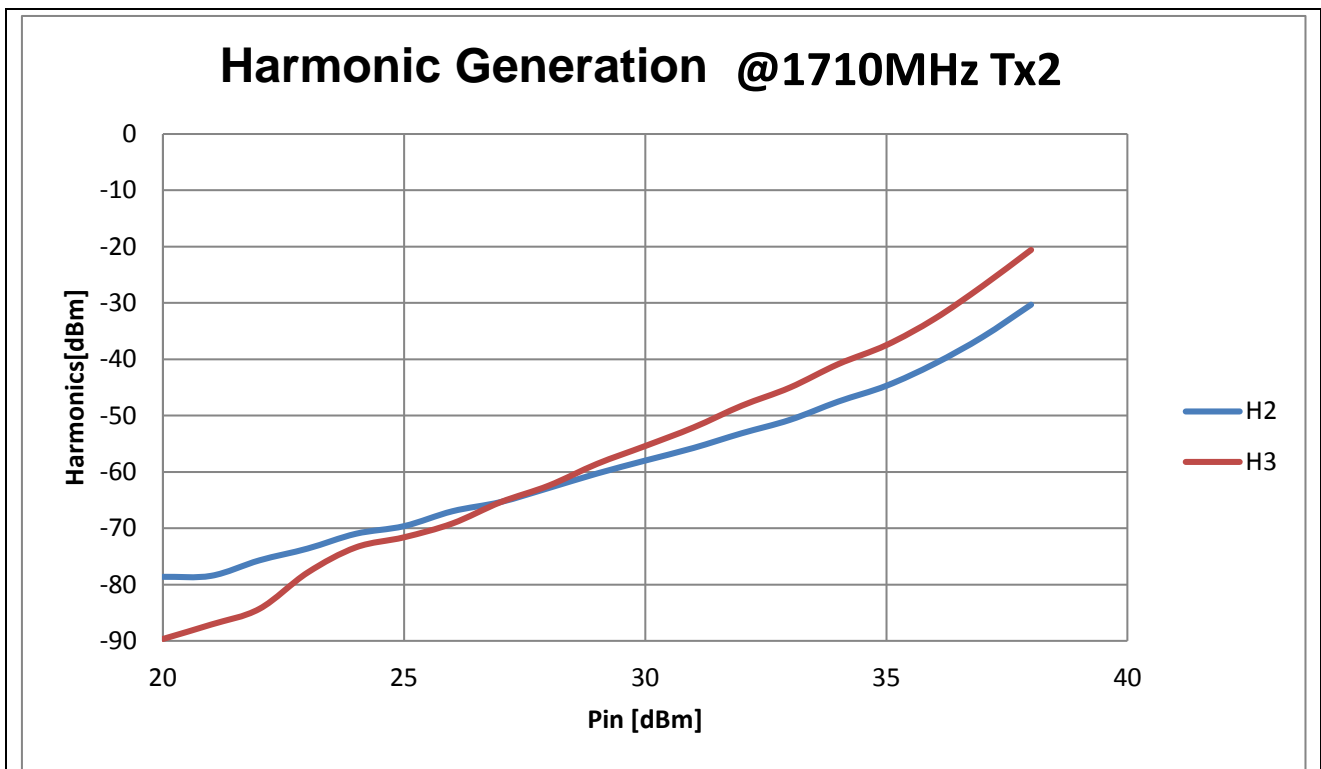


Figure 20 Harmonics at  $f_{in}=1710$  MHz

## 7 Abbreviations

ASM	Antenna Switch Module
CMOS	Complementary Metall-Oxide-Semiconductor
EDGE	Enhanced Data Rates for GMS Evolution
FR4	Material for PCB
GPIO	General Purpose Input Output
GPS	Global Positioning System
GSM	Global System for Mobile Communication
LTE	Long-Term Evolution
LTE-A	LTE Advanced
PA	Power Amplifier
PCB	Printed Circuit Board
SMA	Sub Miniature version A
Rodgers	Material for RF PCBs
RF	Radio Frequency
TD LTE	Time Division LTE
TD-SCDMA	Time Division Synchronous Code Division Multiple Access
TSNP	Thin Small Non Leaded Package
UMTS	Universal Mobile Telecommunications System
W-CDMA	Wideband Code Division Multiple Access
WLAN	Wireless Local Area Network

## **8 Authors**

Andre Dewai, Senior Application Engineer of the Business Unit "RF and Protection Devices"

Ralph Kuhn, Senior Staff Application Engineer of the Business Unit "RF and Protection Devices"

[www.infineon.com](http://www.infineon.com)